



SUPPLIER TO THE FOAM/COATINGS INDUSTRY SINCE 2004

MORSE GENERATORS

TIER 4 FINAL 40KW AND 40CFM DIESEL GENERATOR



MORSE

INDUSTRIAL EQUIPMENT

Our new Tier 4 Final Diesel Generator/Compressor Package features all the same great performance as our Tier 3 package but now in a Tier 4 emissions compliant version!

MODEL GC-40 AND GCRS40-40 T4F DIESEL GENERATOR

FEATURES:

- CUMMINS 3.8L Tier 4 Final Diesel Engine
- Diesel Exhaust Catalyst. No DEF Required
- Meets 2019 Emissions Standards
- High Temperature Coolant Shutdown
- Low Oil Pressure Shutdown
- Totally Enclosed Engine and Generator/Compressor Drive Sections
- New B-CAN Digital Interface for the Air Compressor/Generator
- Cooler Exhaust Plenum Transition for Ease of Ducting Unwanted Heat
- 40kW Generator 220 Volt Rated at 134 amps Three Phase and 141 amps Single Phase
- Remote Mount Volt/Amp/Hz Panel (wiring and external disconnect required)
- 2 Year/2000 Hour Engine Warranty Covered by CUMMINS*
- 1 Year Warranty on All Other Components

MODEL GCRS40-40 T4F

OPTIONAL ROTARY SCREW AIR COMPRESSOR PACKAGE

- Air Compressor Mounted in Tandem with Generator Factory Set at 40 CFM at 125 PSI*
- Compressor Factory Filled with MORSE SCO-1000 Synthetic Oil Rated for 1000 Hour Interval Changes
- Belt Drive Adjustable Tensioner
- Air Cooled Oil Cooler with High Temperature Shutdown

*Engine registration must be initiated with CUMMINS by end user.

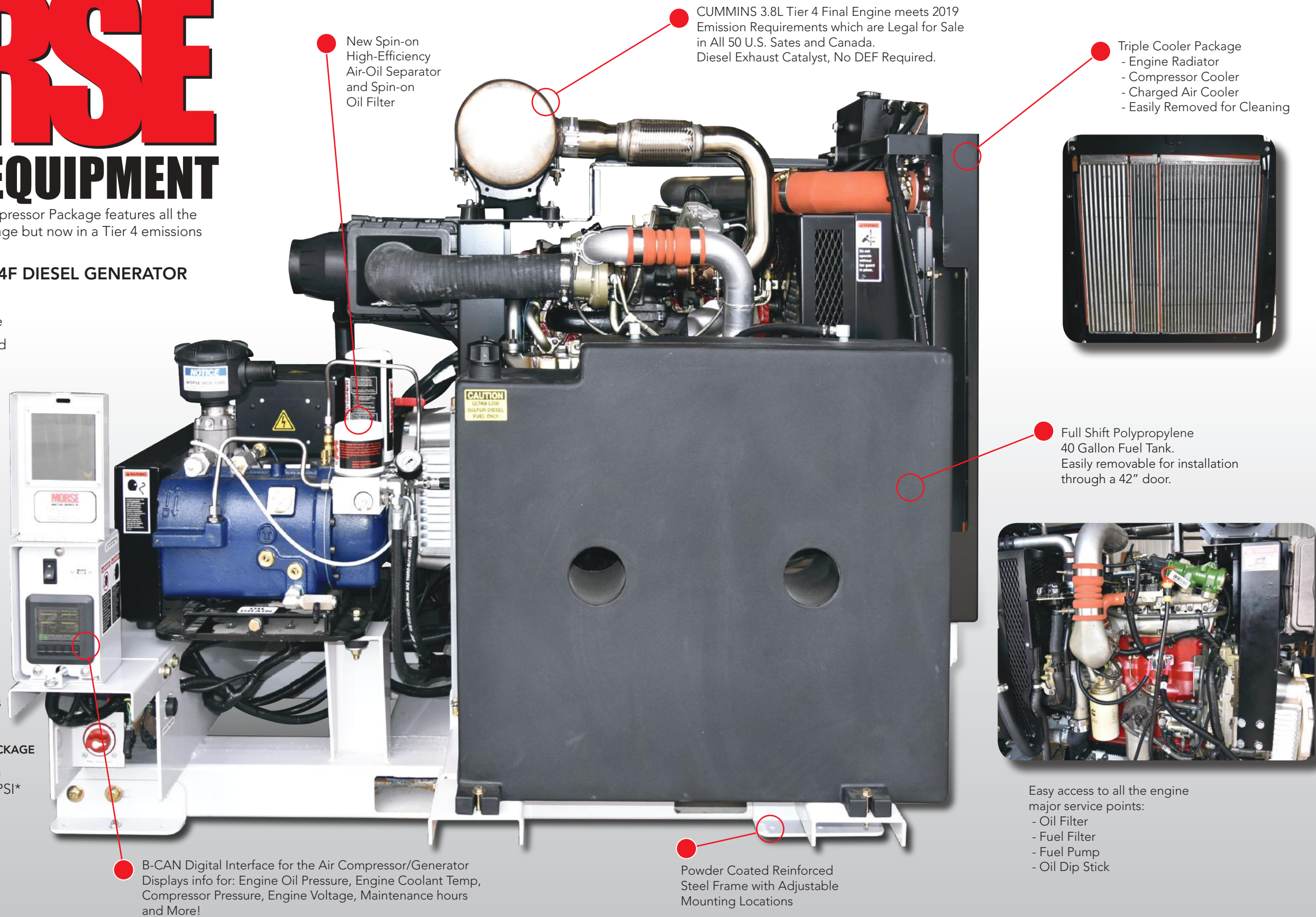

New Spin-on High-Efficiency Air-Oil Separator and Spin-on Oil Filter

CUMMINS 3.8L Tier 4 Final Engine meets 2019 Emission Requirements which are Legal for Sale in All 50 U.S. States and Canada. Diesel Exhaust Catalyst, No DEF Required.

Triple Cooler Package
 - Engine Radiator
 - Compressor Cooler
 - Charged Air Cooler
 - Easily Removed for Cleaning



Full Shift Polypropylene 40 Gallon Fuel Tank. Easily removable for installation through a 42" door.



Easy access to all the engine major service points:
 - Oil Filter
 - Fuel Filter
 - Fuel Pump
 - Oil Dip Stick

B-CAN Digital Interface for the Air Compressor/Generator Displays info for: Engine Oil Pressure, Engine Coolant Temp, Compressor Pressure, Engine Voltage, Maintenance hours and More!

Powder Coated Reinforced Steel Frame with Adjustable Mounting Locations

TIER 4 FINAL COMPLIANT ENGINE 40KW PLUS 40CFM

MODEL GCRS-40-40 T4F DIMENSIONS

Note: Production Models May Vary From Illustrations

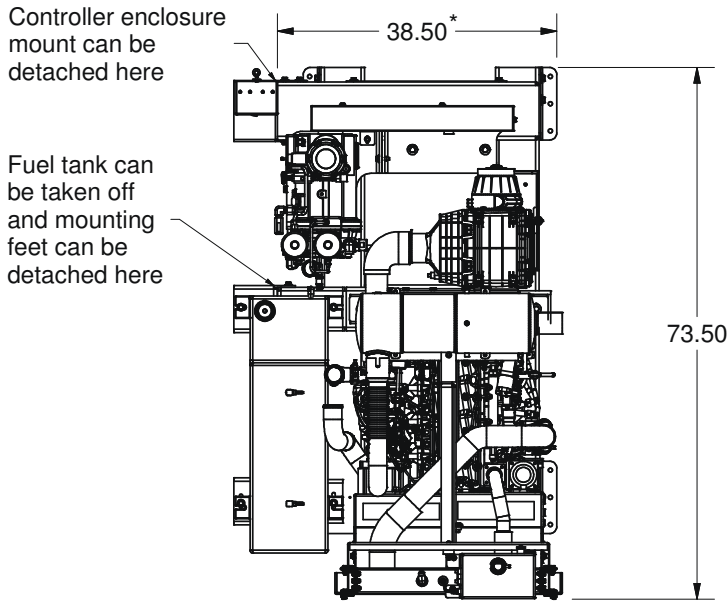

* This is the width of the machine with the fuel tank and controller enclosure removed

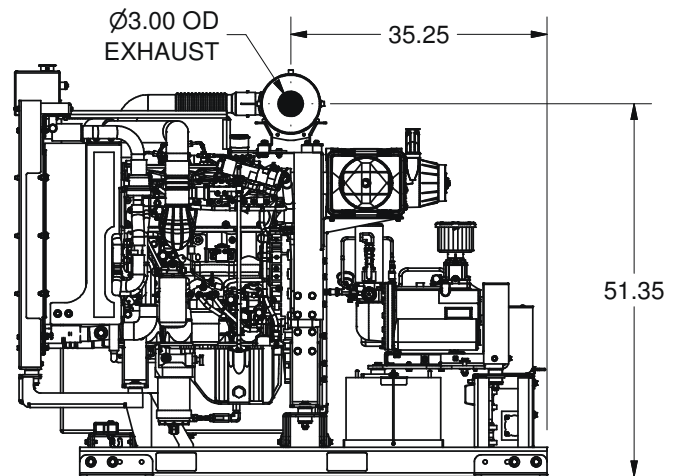
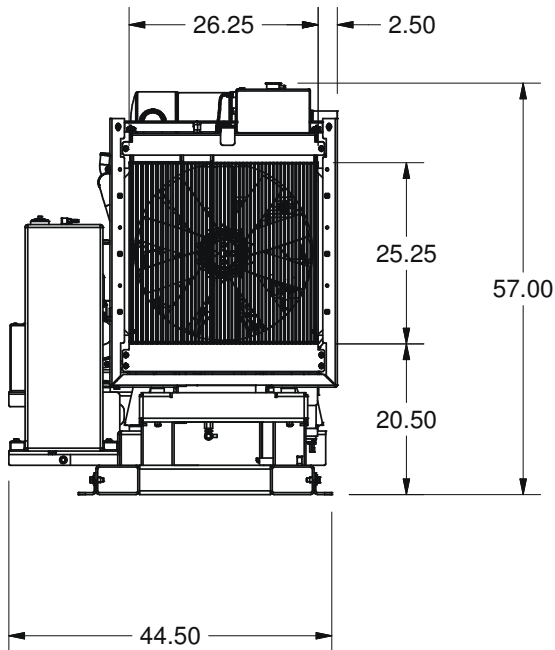
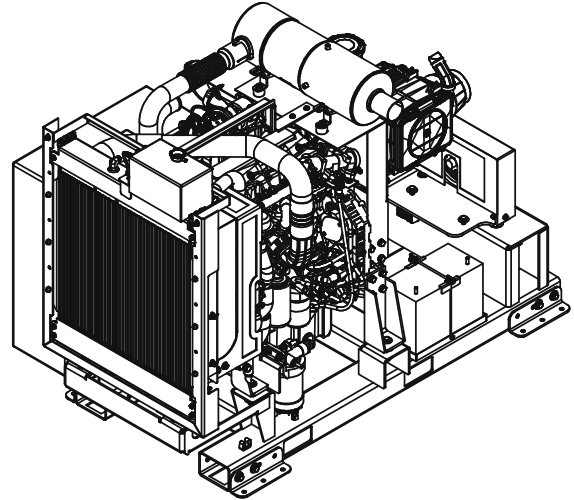

WEIGHT GCRS-40 1770 LBS
 GCRS-40-40 T4F 2070 LBS
 *without fuel

For additional information, contact your authorized Morse Industrial Equipment Dealer



MORSE

INDUSTRIAL EQUIPMENT

www.morseindustrial.ca

P.O. Box 1519 Stn Main
 Antigonish, Nova Scotia, Canada B2G 2L8
 Ph. 647-393-1212 Fax: 902-867-6211